

TRIPAC FIG. TP-110 STANDARD U-BOLT WITH 4 HEX NUTS

SIZE RANGE-1/2" THRU 36" PIPE

SERVICE-DESIGNED FOR SUPPORT, ANCHOR OR GUIDE OF PIPE.

MATERIAL-CARBON STEEL, T-304, AND T-316

FINISHES-PLAIN, ELECTRO-GALVANIZED, HDG

MAXIMUM TEMPERATURE-750°

NOTE-WHEN FURNISHED IN HDG FINISH, OVERSIZE TAPPED HEX NUTS MUST BE USED.

COMPLIES WITH FEDERAL SPECIFICATION WW-H-171E, (TYPE 24), AND MANUFACTURERS STANDARDIZATION SOCIETY SP-69, (TYPE 24).

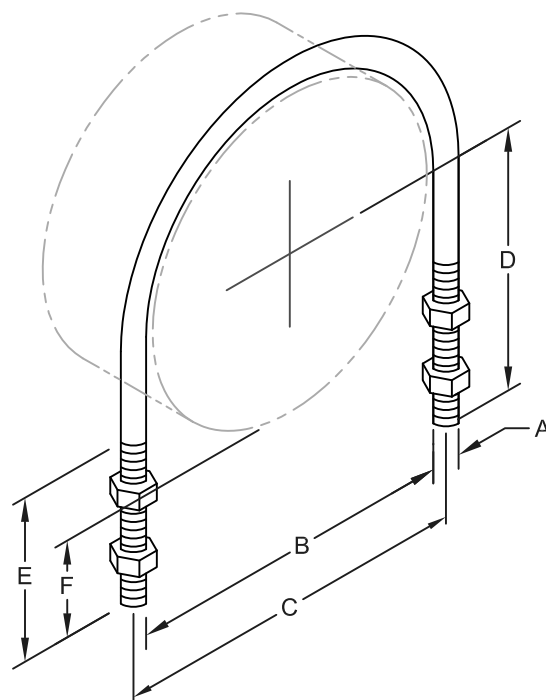

DIMENSIONS & WEIGHTS

ROD SIZE A	PIPE SIZE	B	C	D	E	F	MAX. REC. LOAD LBS. FOR SERVICE TEMPS.		APPROX. WT./100
							650°F / 343°C	750°F / 399°C	
1/4"	1/2"	15-16"	1-3/16"	2-3/4"	2-1/8"	2-5/16"	485	435	11
1/4"	3/4"	1-1/8"	1-3/8"	2-3/4"	2-1/8"	2-7/32"	485	435	12
1/4"	1"	1-3/8"	1-5/8"	2-3/4"	2-1/8"	2-3/32"	485	738	12
3/8"	1-1/4"	1-11/16"	2-1/16"	2-7/8"	2-1/8"	2-1/32"	1220	1090	28
3/8"	1-1/2"	2"	2-3/8"	3"	2-1/2"	2-1/16"	1200	1090	30
3/8"	2"	2-7/16"	2-13/16"	3-1/4"	2-1/2"	2-1/16"	1220	1090	33
1/2"	2-1/2"	2-15/16"	3-7/16"	3-3/4"	3"	2-5/16"	2260	2020	85
1/2"	3"	3-9/16"	4-1/16"	4"	3"	2-1/4"	2260	2020	93
1/2"	3-1/2"	4-1/16"	4-9/16"	4-1/4"	3"	2-1/4"	2260	2020	101
1/2"	4"	4-9/16"	5-1/16"	4-1/2"	3"	2-1/4"	2260	2020	110
1/2"	5"	5-5/8"	6-1/8"	5"	3"	2-7/32"	2260	2020	124
5/8"	6"	6-3/4"	7-3/8"	6-1/8"	3-3/4"	2-13/16"	3620	3230	200
5/8"	8"	8-3/4"	9-3/8"	7-1/8"	3-3/4"	2-13/16"	3620	3230	230
3/4"	10"	10-7/8"	11-5/8"	8-3/8"	4"	3"	5420	4830	486
7/8"	12"	12-7/8"	13-3/4"	9-5/8"	4-1/4"	3-1/4"	7540	6730	790
7/8"	14"	14-1/8"	15"	10-1/4"	4-1/4"	3-1/4"	7540	6730	850
7/8"	16"	16-1/8"	17"	11-1/4"	4-1/4"	3-1/4"	7540	6730	935
1"	18"	18-1/8"	19-1/8"	12-5/8"	4-3/4"	3-5/8"	9920	8850	1360
1"	20"	20-1/8"	21-1/8"	13-5/8"	4-3/4"	3-5/8"	9920	8850	1476
1"	24"	24-1/8"	25-1/8"	15-5/8"	4-3/4"	3-5/8"	9920	8850	1698
1"	30"	30-1/8"	31-1/8"	18-5/8"	4-3/4"	3-5/8"	9920	8850	2027
1"	36"	36-1/8"	37-1/8"	21-5/8"	4-3/4"	3-5/8"	9920	8850	---

TRIPAC

475 KLUG CIRCLE • CORONA, CA 92880-6406
(951) 280-4488 • FAX: (951) 272-4445

A DIVISION OF TRIPAC MARKETING, INC.

WWW.TRIPACONLINE.COM