

TRIPAC FIG. TP-272SS ADJUSTABLE ROLLER HANGER

SIZE RANGE-4" THRU 20" PIPE

SERVICE-DESIGNED FOR SUSPENSION OF PIPE WHERE LONGITUDINAL MOVEMENT OF PIPE MAY OCCUR DUE TO EXPANSION AND CONTRACTION, AND WHERE VERTICAL ADJUSTMENT MAY BE NECESSARY. EXCELLENT CORROSION RESISTANCE.

MATERIAL-ALL 304 STAINLESS STEEL CONSTRUCTION.

COMPLIES WITH FEDERAL SPECIFICATION WW-H-171-E (TYPE #44), A-A-1192 A (TYPE #43) AND MANUFACTURERS STANDARDIZATION SOCIETY MSS SP-58 AND SP-69 (TYPE #43)

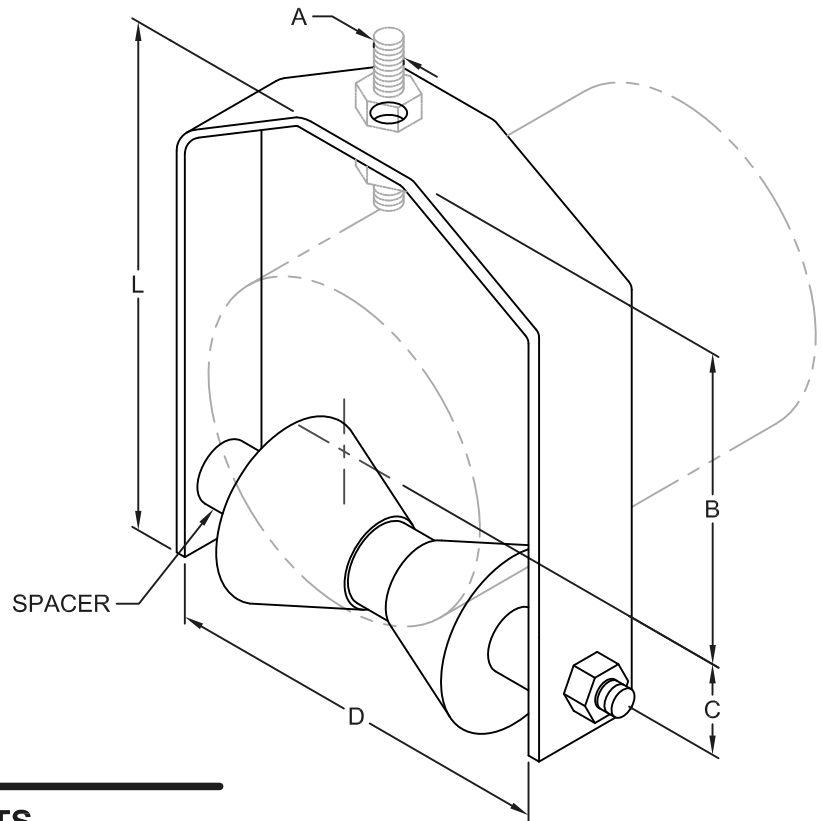

DIMENSIONS & WEIGHTS

PIPE SIZE	A	B	C	D	L	CROSS ROD DIA.
4"	5/8"	5-3/16"	2-13/16"	4-7/8"	9-1/4"	3/4"
6"	3/4"	6-7/16"	3-15/16"	7"	11-5/8"	3/4"
8"	7/8"	7-1/2"	5-1/4"	9"	14"	7/8"
10"	7/8"	8-3/4"	6-3/8"	11"	16-1/2"	7/8"
12"	7/8"	10-1/16"	7-7/16"	13"	18-7/8"	1-1/8"
14"	1"	10-15/16"	8-3/16"	14-1/4"	20-5/8"	1-1/8"
16"	1"	12-13/16"	9-5/16"	16-1/4"	24-3/8"	1-1/4"
18"	1"	13-3/4"	10-3/8"	18-1/4"	26-1/8"	1-1/4"
20"	1-1/4"	15-1/16"	11-5/16"	20-1/4"	28-11/16"	1-1/4"

TRIPAC

475 KLUG CIRCLE • CORONA, CA 92880-6406
(951) 280-4488 • FAX: (951) 272-4445

A DIVISION OF TRIPAC MARKETING, INC.

WWW.TRIPACONLINE.COM